

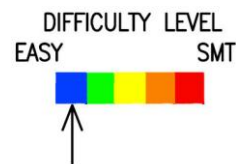

QRPGuys K7QO Simple Straight Key Code Practice Oscillator

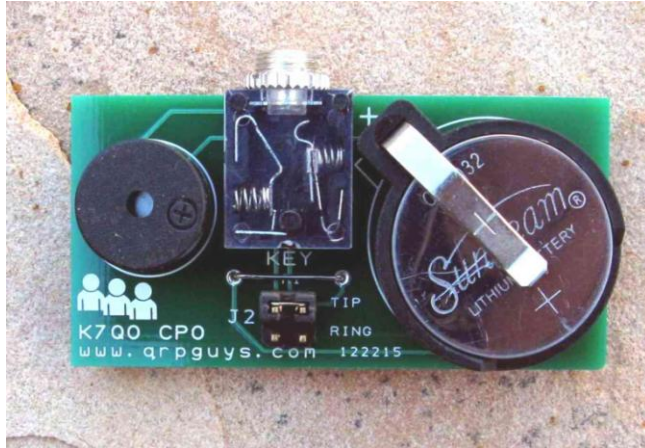

First, familiarize yourself with the parts and check for all the components. If a part is missing, please contact us and we will send one. You must use qrpguys.parts@gmail.com to request a part.

Parts List

- 1 – QRPGuys Code Practice Oscillator PCB
- 1 – Piezo oscillator speaker
- 1 – J1, 3.5mm stereo jack
- 1 – CR2032 coin battery holder
- 1 – header jumper (Berg connector)
- 2 – 2 pin header strip
- 4 – 6mm dia. self adhesive foot

The tools you will need are a soldering iron with a small tip, rosin core solder, and side cutters. Assembly time less than 1/2 hour.

Start with the smallest components first, using the figure below as a guide.

- [] Install the two 2 pin header strips at J2.
- [] Install 3.5mm stereo jack at J1
- [] Install the piezo oscillator speaker. Observe the polarity marking on the top of the device and match it to the “+” marked hole on the PCB.
- [] Install a jumper at R1 for full volume. You may try any value of 0-50 ohms for lower volume.

- [] Install the CR2032 battery holder.
- [] Apply the 6mm self adhesive feet to the corners on the backside, and install a CR2032 lithium coin battery.

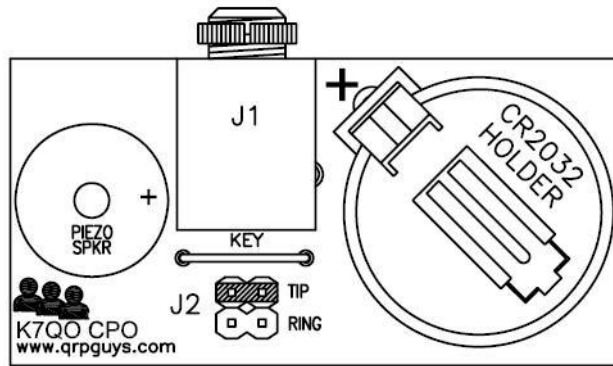

This completes the assembly.

This simple code practice oscillator is designed for a straight key. You can wire your key to a mono or stereo 3.5mm plug. Wire one side of your key to the sleeve connector and the other side of your key to either the tip or ring solder lug of the plug you are using. The board can accommodate the tip or ring connection being used on a stereo connector, or the sleeve and tip connection on a mono connector. Simply place the jumper on the appropriate header.

Prepare your key:

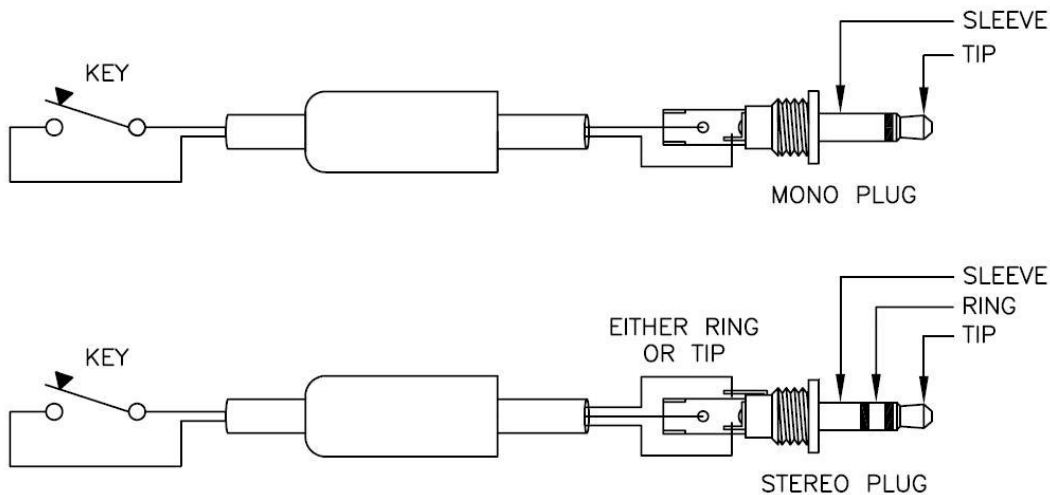

Schematic:

