

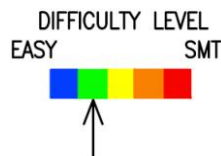

QRPGuys LED Tuning Indicator Assembly Manual

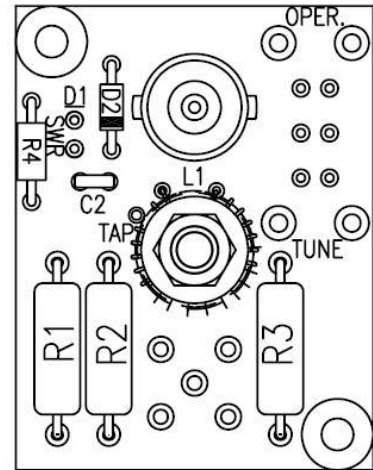
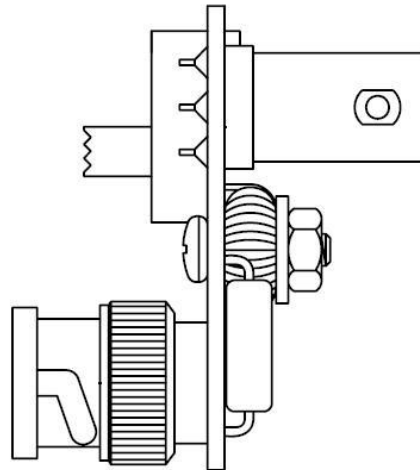
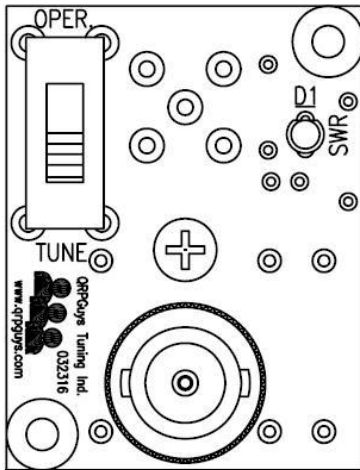

First, familiarize yourself with the parts and check for all the components. If a part is missing, please contact us and we will send one. You must use qrpguys.parts@gmail.com to request a part.

Parts List

- 1 – QRPGuys Tuning Indicator PCB
- 1 – Slide switch – DPDT
- 1 – FT37-43 toroid core (black)
- 1 – 24" of 26AWG magnet wire for the toroids
- 1 - BNC PCB male connector
- 1 - BNC PCB female connector
- 1 – 4-40 x 1/2" long nylon screw
- 1 – 4-40 nylon nut
- 1 – 3/8" diameter #4 nylon washer
- 1 – C2, .1uF mono capacitor, marked 104, there is no C1
- 1 – D1, Red LED w/clear lens
- 1 – R4, 470 ohm resistor (yellow-violet-brown-gold)
- 3 – R1-3, 51 ohm 2W power resistor (green-brown-black-gold, or value is printed on the component)
- 1 – D2, 1N4148 signal diode, sm. glass, w/black band on one end

We will assemble the smallest components first. **Not all components are on the same side of the board.**

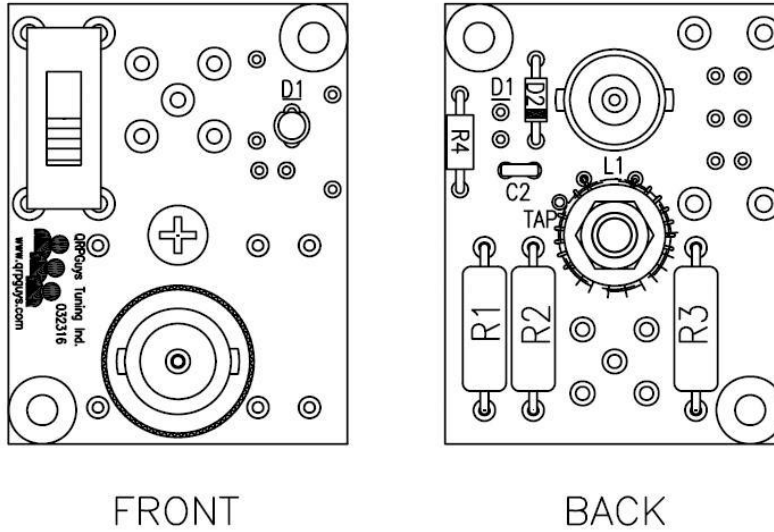

There is one user decision to make for two components, the (LED indicator and TUNE/OPER. Switch) you may wish to mount on one side or the other, depending how you want the visibility or ease of use. These two components will work on either side electrically the same. The unit is designed so that it can be mounted on the rear of your radio's BNC connector. If you have a small radio you may choose to mount the LED and switch facing the front of your radio towards the operator. Given the small size of the unit, you may opt to mount these two components to the rear so they can be seen easier. The instructions are written for these two components facing on the front, towards the operator.

Start with the back of the board. Use the figure above to aid in the parts placement.

- [] Install C2, .1uF, marked 104, there is no C1
- [] Install D2, 1N4148 signal diode, observing the black polarity band (cathode) location as shown above.
- [] Install R4, 470 ohm resistor (yellow-violet-brown-gold)
- [] Install R1 – R3, 51 ohm, 2W, power resistor

On the front of the board, install the following:

- [] Install D1, the clear lens LED on the front side of the board. The polarity must be correct. The short lead is "negative" and goes towards the top of the board. There is also a very small flat indicating the negative side of the led, and a bar silkscreened indicating the flat on the board. Seat the LED flush with the surface of the board.
- [] Install S1 the slide switch, soldering all four corners and electrical pins.

Next you assemble the toroid on the back side of the board.

- [] For L1, use the FT37-43 (black) core and 24" of the supplied magnet wire. You are winding a total of **25** turns, with a tap at **5** turns from the beginning of winding. Remember, every time the wire goes through the center of the core, it counts as one turn. The picture, and figure below shows the beginning of winding and the twisted technique for the tap. The total of 25 turns will completely fill the toroid.

Note: Now is a good time to mention a good way for counting the turns on your toroids. Many times on toroids with a lot of turns, you lose track going around, as some are quite small. A good trick is to take a digital picture of it and blow it up on your computer screen. Counting is clearly a lot easier.

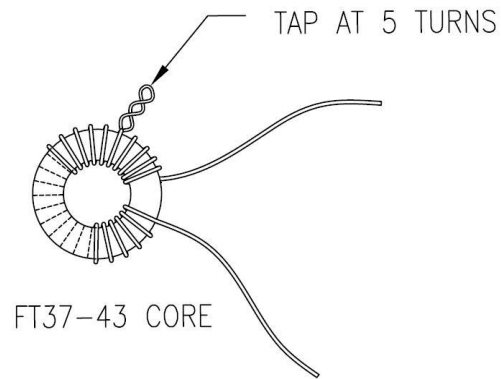
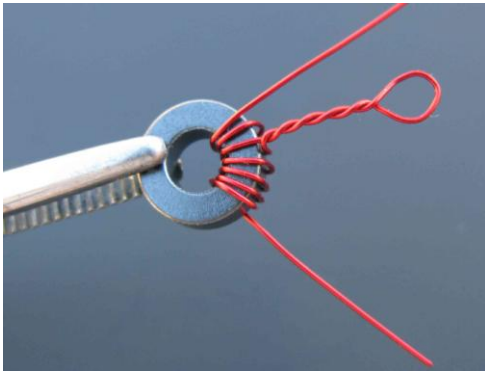

- [] Bend the leads as shown below, trim to 1/4" long, and tin the leads prior to soldering them to the backside of the board. The magnet wire supplied is Thermaleze® brand and will tin easily with a soldering iron. Always tin the leads before trying to solder them in place and you will greatly eliminate any continuity problems.



- [] Solder L1 where indicated on the PCB, and centered on the screw hole. You will notice the tap hole is indicated, and is slightly larger in diameter to accept the double twisted wire. Install the toroid flush with the backside of the board. **Do not elevate it off the board.** You will be securing it with a nylon screw, nylon washer and nut.

- [] Secure L1 to the back side of the board using the 4-40 nylon screw, nylon washer, and nylon nut, as shown below. Tighten enough to secure and protect the toroid, but do not over tighten.

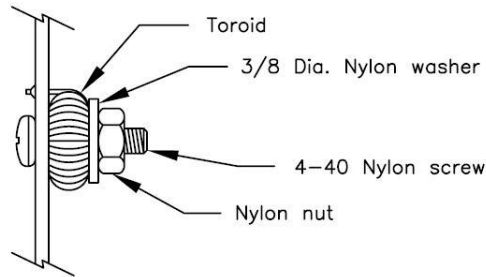

Turn your soldering iron temperature up to solder the two BNC connectors. The four ground connections on the outside are part of the metal shell and require more heat than ordinary leaded components.

- [] Install the male BNC connector flush with the front side of the board.
- [] Install the female BNC connector flush with the rear side of the board.

This completes the electrical and mechanical assembly.

Schematic:

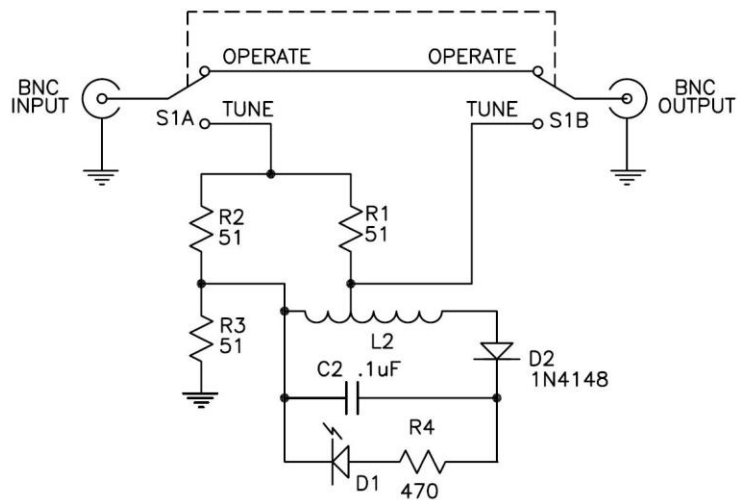

LED Tuning Indicator Usage

This was designed for use with an antenna tuner that does not have an SWR indicator, or tuning your antenna with your rig to run without a tuner. Place this device in between your radio and tuner or in between your radio and antenna if you do not use a tuner to indicate the relative SWR of your antenna and feed line. The tuner is rated at 10 watts PEP max., 5 watts CW and incorporates a LED absorption bridge circuit for sensing SWR. In the TUNE position, you cannot damage your transmitter caused by a high SWR. The worst your transmitter is looking at is a maximum of 2:1 SWR in the TUNE position. The LED is only showing reflected power. At full brilliance your SWR is 4:1 or greater, at half brilliance your SWR is approximately 2:1, and the LED will completely extinguish at 1:1. *Tip from Dan...If your led does not completely go out at 1:1 there may be a little too much gain on L1, the indicator transformer. Just reduce the turns on the high side of the tap, one or two turns.*

Additionally, after the antenna is tuned up, keeping the bridge in the circuit, in the (Tune position) will reduce the power by a factor of four to a matched antenna. This can occasionally be useful when trying to bring a 3w QRP transmitter to under the 1w level for certain sub-one watt contest multipliers.