

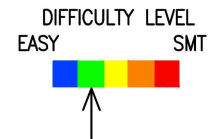

## QRPGuys Backpack CLV Antenna Assembly Manual

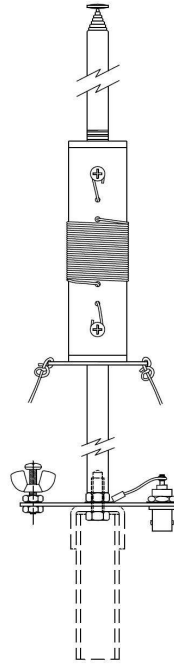
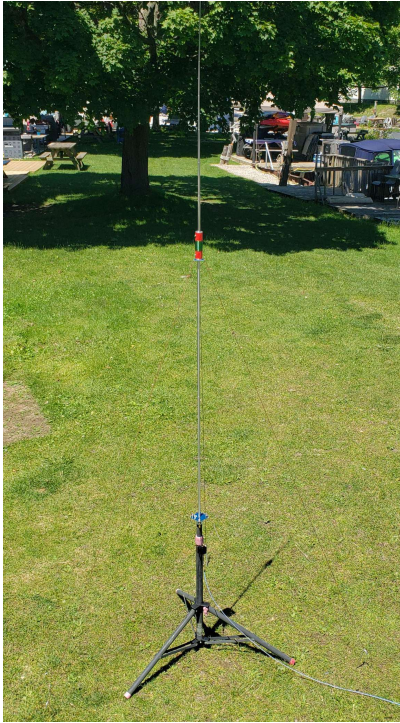

First, familiarize yourself with the parts and check for all the components. If a part is missing, please contact us and we will send one. To request a part, please use [qrpguys.parts@gmail.com](mailto:qrpguys.parts@gmail.com).

### Parts List

- 1 – QRPGuys CLV base mount pcb
- 1 – QRPGuys CLV guy pcb
- 4 – Ø10mm x 30cm threaded rod extensions
- 1 – 4" long x 1" PEX tubing
- 1 – aluminum PEX plug with 4mm tapped hole
- 1 – aluminum PEX plug with 6mm tapped hole
- 1 – telescoping antenna element, w/M4 female thread
- 1 – BNC female chassis connector
- 2 – 6-32 x .31" long SS hex bolt
- 2 - #6 SS flat washer
- 1 – 4mm x 16mm long SS pan head screw
- 1 – M6 x 20mm SS hex bolt
- 1 - M6 SS lock washer
- 1 – M6 SS nut
- 3 – 8-32 x .75 long SS pan head screw
- 6 – 8-32 SS nuts
- 3 – 8-32 SS wing nut
- 4 - #8 internal tooth SS lock washer
- 1 – solid tinned wire, 2"long
- 1 - Ø.25 solder lug
- 1 – 22awg magnet wire
- 1 – Ø1.25" x 3" long clear heat shrink tubing

Tools required are, an electric drill, 3-32" drill bit, 6-32 tap, phillips screwdriver, needle nose pliers, soldering iron, solder.

The graphic below shows the scope of the antenna project. The instructions below, if followed, will insure a successful outcome. Please read them carefully before proceeding.

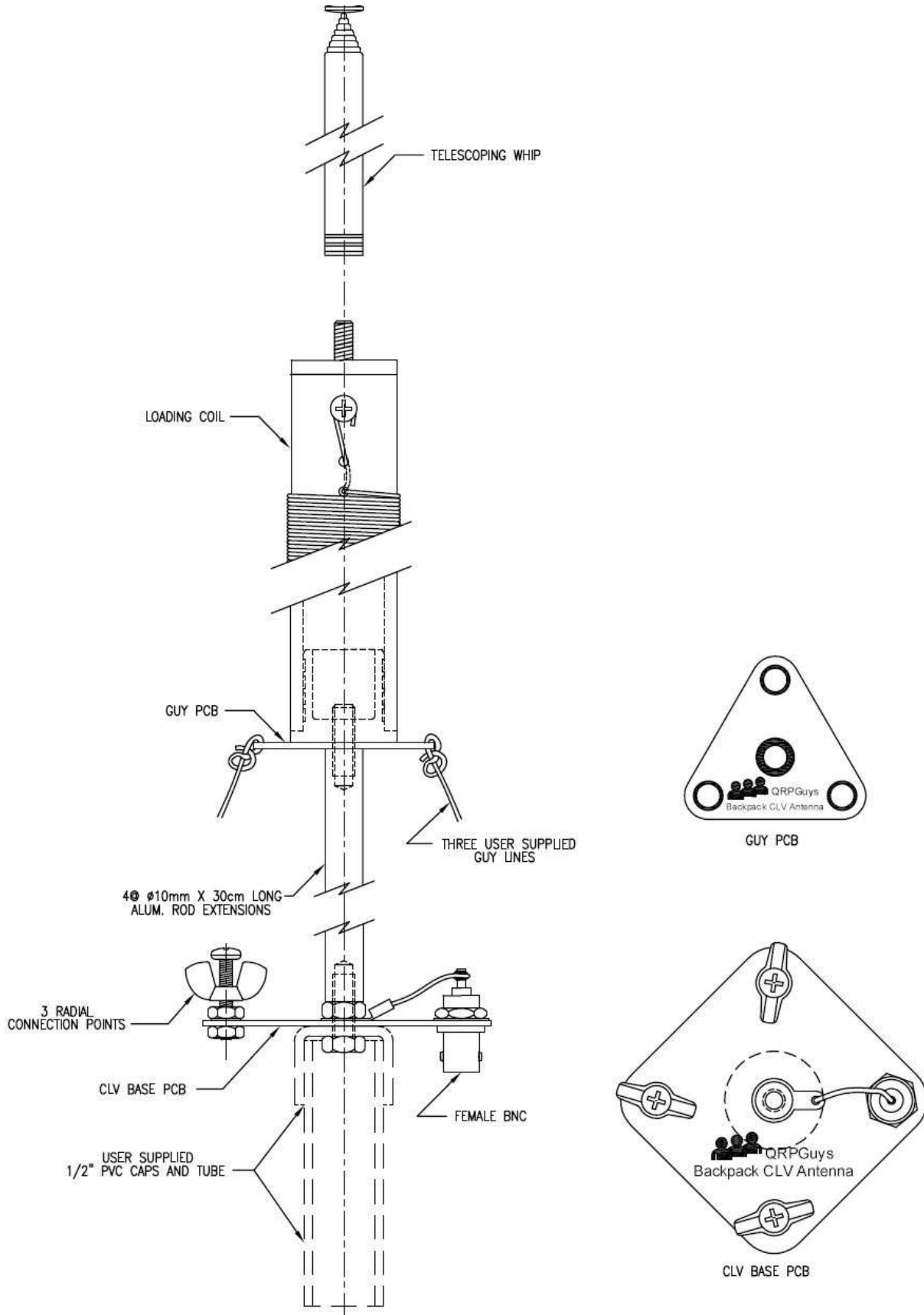

You will start with the loading coil first.

- [ ] Thread the 4mm x 16mm long screw, and #8 lock washer into the PEX plug with the 4mm tapped hole from the inside. Hold the PEX plug where shown below with pliers and tightly secure the screw.

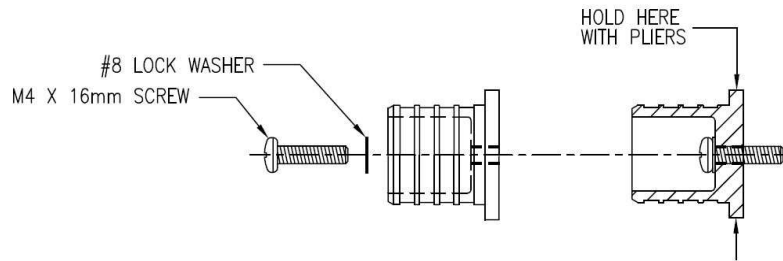

- [ ] Press both PEX plugs into the 4" length of PEX pipe. Carefully measure and mark the PEX pipe as shown below, from each end of the assembly, and drill the six holes  $\text{Ø}3/32''$ , through the PEX and aluminum to the inside only.

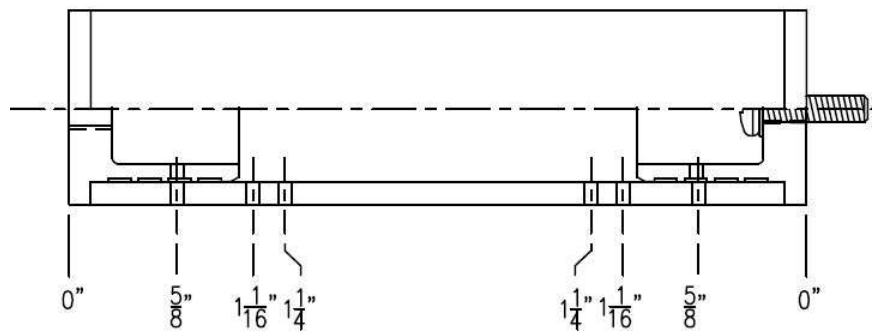

- [ ] Tap the two end hole locations with the 6-32 tap. *Tap those locations only.*

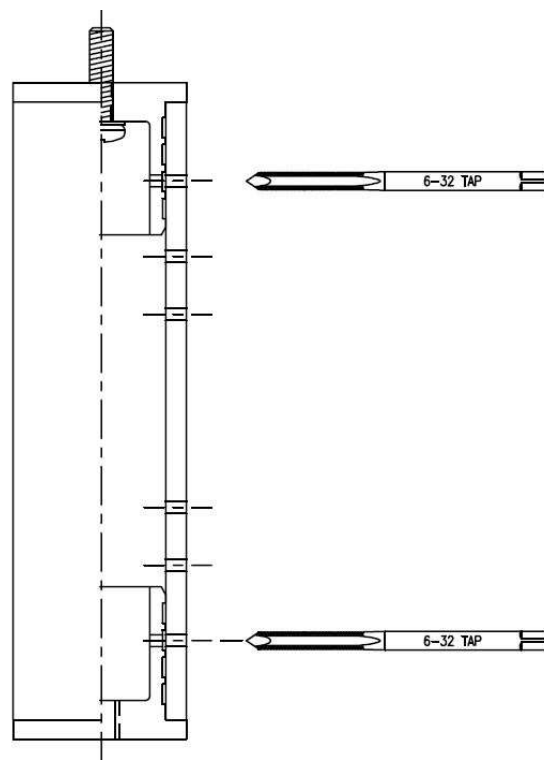

- [ ] Mark the plug with the larger threaded hole and that end of the tube, so you don't mix the plugs after you drilled. Then remove both PEX plugs. Snake one end of the 22awg magnet wire into the hole shown, and back out the other hole. Re-install the PEX plug with the large threaded hole, and remove 1/2" of the enamel insulation from the wire and secure with the 6-32 screw and #6 washer with the wire *between* the washer and screw head as shown below.

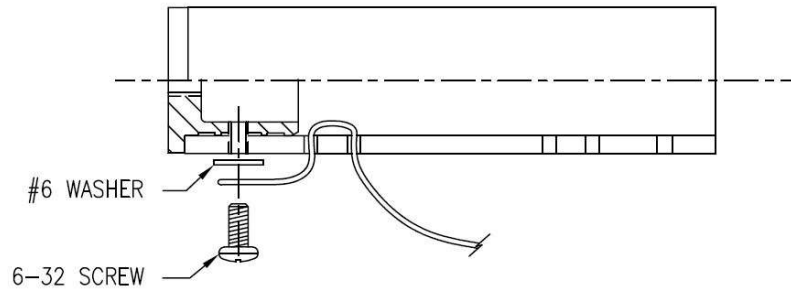

- [ ] Wind a total of **51 turns**, close wound, and feed the far end of the magnet wire down thru the hole location shown to the inside, and back to the outside thru the next hole. You can now trim, leaving 3" of the 22awg magnet wire. Re-install the PEX plug, making sure the 6-32 hole aligns. *Double check your turn count. When counting coil turns, it is easy to make a mistake. I find it helpful to take a sharp, close-up picture, and print it. It's a lot easier to count.*

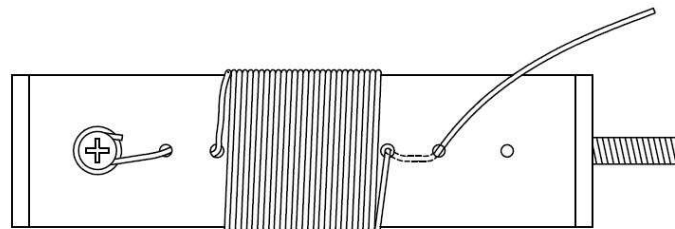

- [ ] Again, remove 1/2" of the enamel insulation from the wire where the wire wraps around the screw and secure this end with the 6-32 screw and washer.

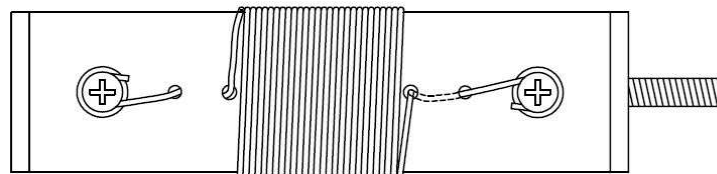

- [ ] The coil gets covered with clear heat shrink tubing. Center the sleeve and shrink it to the assembly.

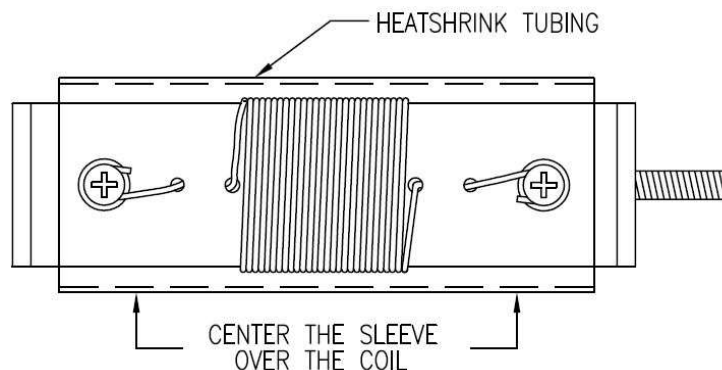

This completes the loading coil assembly.

Refer to the graphic below and assemble the base plate as shown:

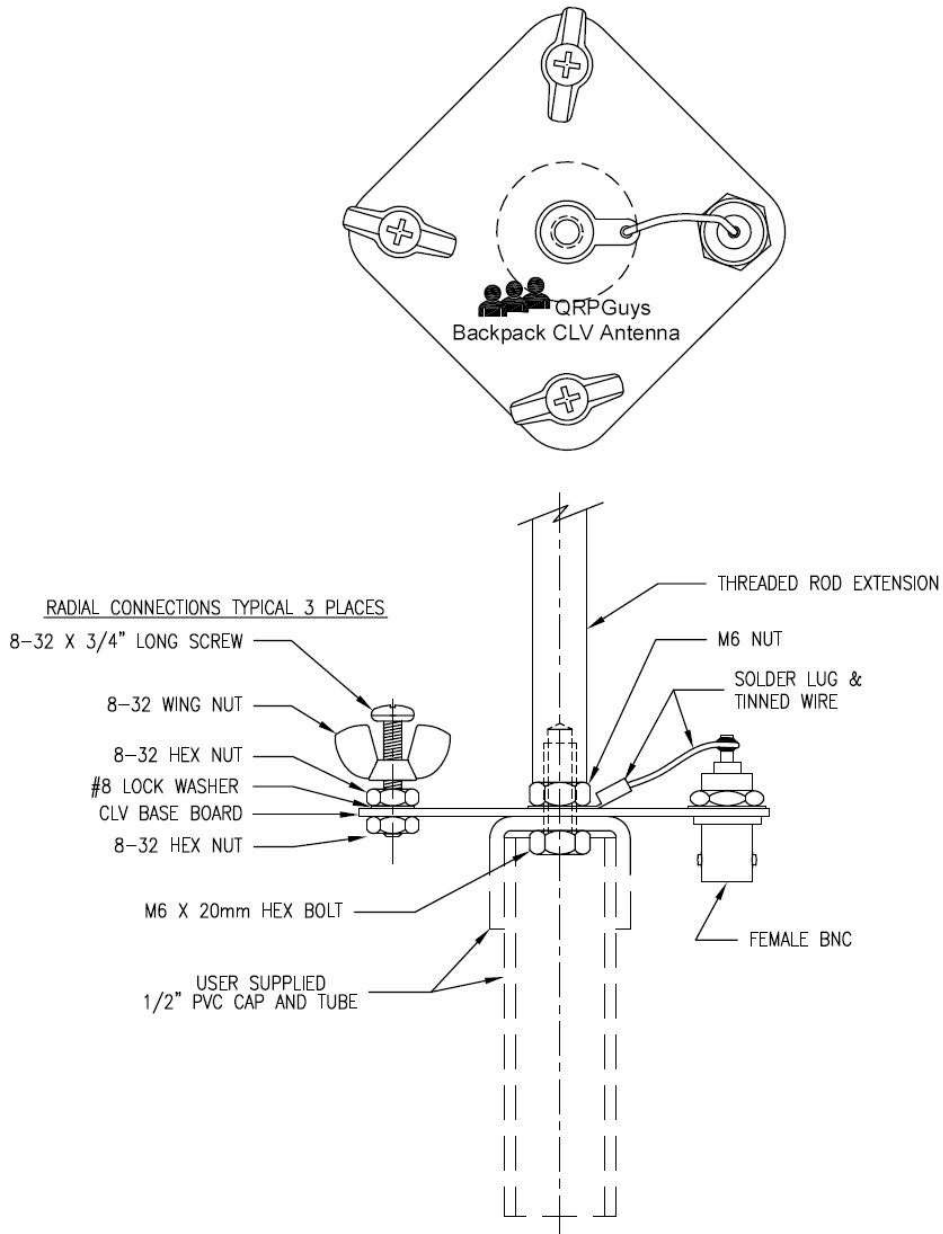

- [ ] Mount the female BNC connector with the nut and lock washer in the larger corner hole. If a solder lug came with the connector, do not use it.
- [ ] Temporarily mount the M6 hex bolt from the bottom of the base pcb, with the 1/4" solder lug on the top side of the board and secure it with the M6 SS nut. Point the solder lug hole towards the BNC connector.
- [ ] Solder the supplied tinned solid wire from the solder lug under the M6 nut to the center pin of the female BNC connector.
- [ ] Mount the three 8-32 SS screw assemblies as shown in the three remaining corner holes. Using the sequence shown will prevent loss of the SS wing nuts.

This completes the base assembly.

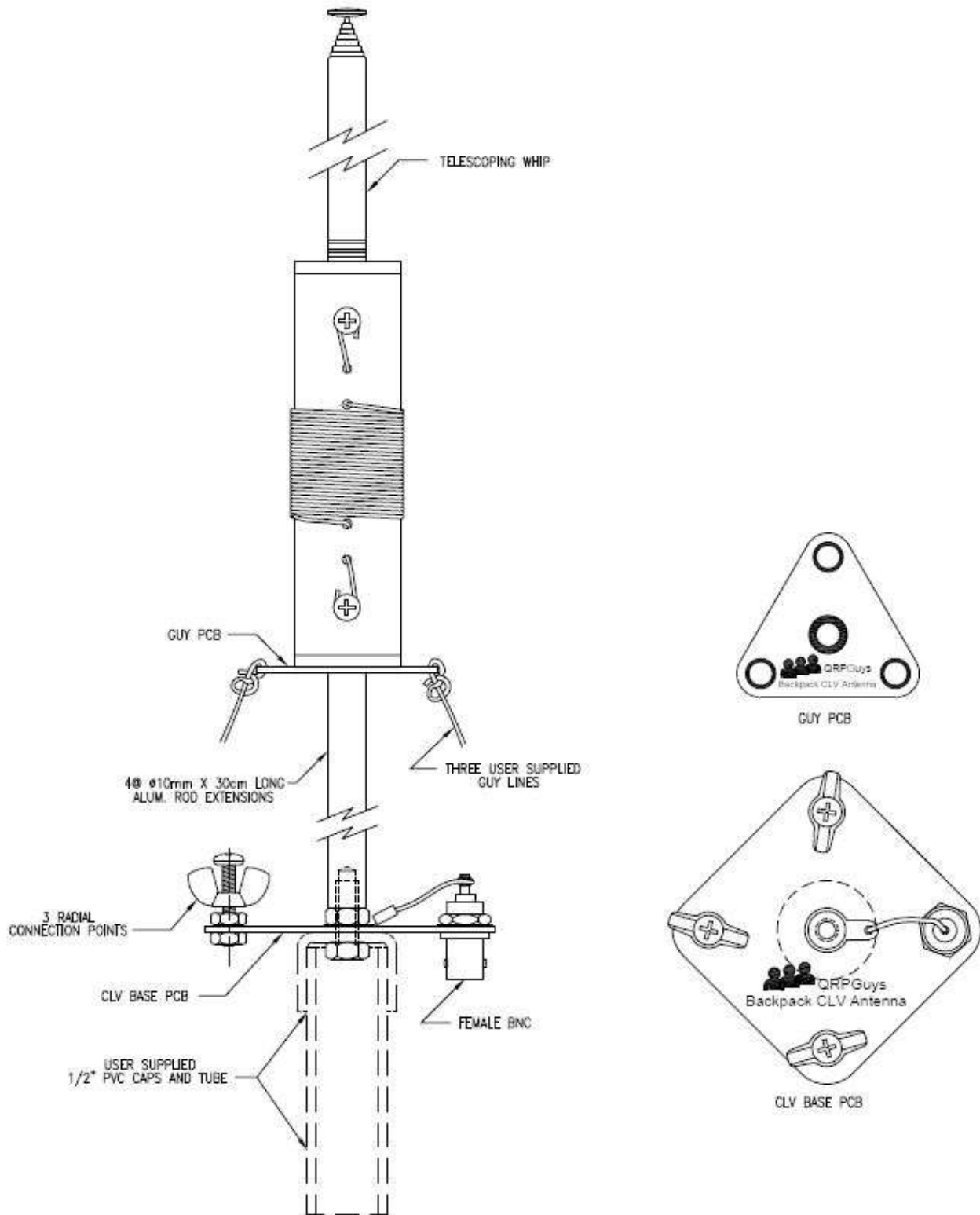

Referring to the graphic above, the four sections of aluminum rod screw together and are secured to the base PCB on top of the M6 SS nut. This antenna needs to be guyed if there is any wind. Light cord is all that is required. The smaller triangular board mounts between the top aluminum rod and the bottom of the loading coil as shown on the right side of the graphic above, and provides for three spaced guy lines. The telescoping antenna mounts on top of the loading coil. The three 8-32 wing nut hardware points are for the required radials. Multiple radials can be attached at each of the three points for a broad network if desired. The telescoping whip antenna mounts on top of the loading coil.

## SETUP:

At this point you need to decide how you would like to deploy the antenna. The least expensive way is shown below, using two 1/2" PVC caps, a piece of 1/2" PVC pipe, and a short piece of 1/4" threaded rod, or a 1/4" bolt with the head cut off. There is no need to cement the 2 caps and tube together, as they press together, stay secure, and can pull apart for compact storage. You will need to guy this option

Alternatively, leaving off the bottom cap and spike,, the 1/2" PVC tube will slide into the end tube of the Husky Portable Light Tripod from Home Depot, part# 1001 863 391. Light guy lines are also advised for support in any wind.

If you decide to roll your own mounting scheme, remember that the 6mm center bolt must be protected from ground, as it is connected to the center radiating element.

Radials must be used. The three 8-32 wing nut hardware points are for the radial connections. If desired, multiple radials can be attached at each of the three points for a broad network if desired.

During testing the typical set-up I used was as follows:

- Husky Portable Light Stand 24" high, with the 1/2" PVC pipe into the center tube, outdoors, away from any buildings. Three 12ft. radials equally spaced, RG174 feed coax 30ft. long, w/clamp-on ferrite
- Resonant 40m operation is adjusted by the whip length and is easily affected by any assembly and environmental variables. Radial count, length, and placement can also affect resonance. My results as follows:
- 7.060 MHz, whip 40", SWR 1.2:1
- 7.150 MHz, whip 39", SWR 1.2:1
- 7,225 MHz, whip 38", SWR 1.2:1

