

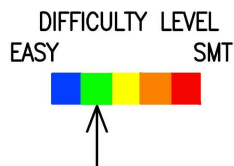

## QRPGuys (tr)uSDX Aluminum Case

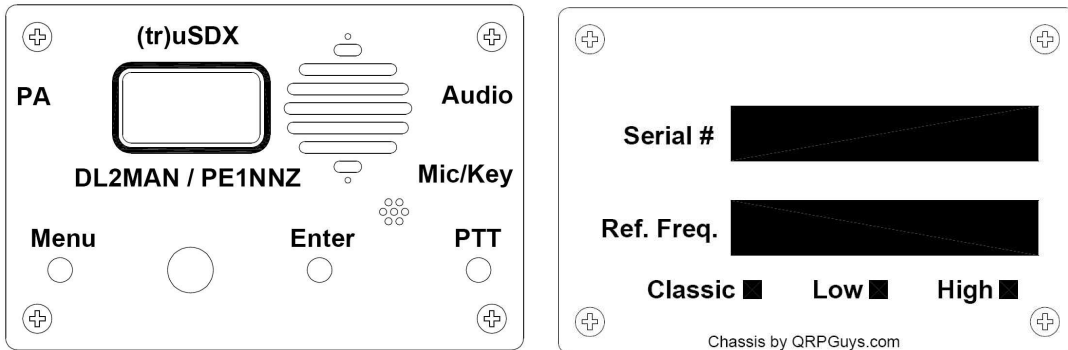

First, familiarize yourself with the parts and check for all the components. If a part is missing, please contact us and we will send one. To request a part, please use [qrpguys.parts@gmail.com](mailto:qrpguys.parts@gmail.com). Please read all the instructions carefully, and do not proceed if you are unsure.

### Parts List

- 1 – QRPGuys (tr)uSDX top cover, bottom cover, side assembly
- 4 – M3 x 6mm long non-threaded round nylon spacer
- 4 – M3 x 6mm long M/F threaded hex nylon spacer
- 4 – M3 x 12mm long threaded hex nylon spacer
- 4 – M3 x 12mm long Phillips flat head SS screw
- 4 – M3 x 6mm long Phillips flat head SS screw
- 2 – M3 x 5mm long ultra thin pan head Phillips SS screw
- 4 – 009 size o-ring
- 4 – self-adhesive rubber foot

The only tool required is a small Phillips screwdriver

The scope of this kit, involves removing the pc boards from the 3D printed case if you purchased that option, or from a kit without a case. Read the instructions carefully.

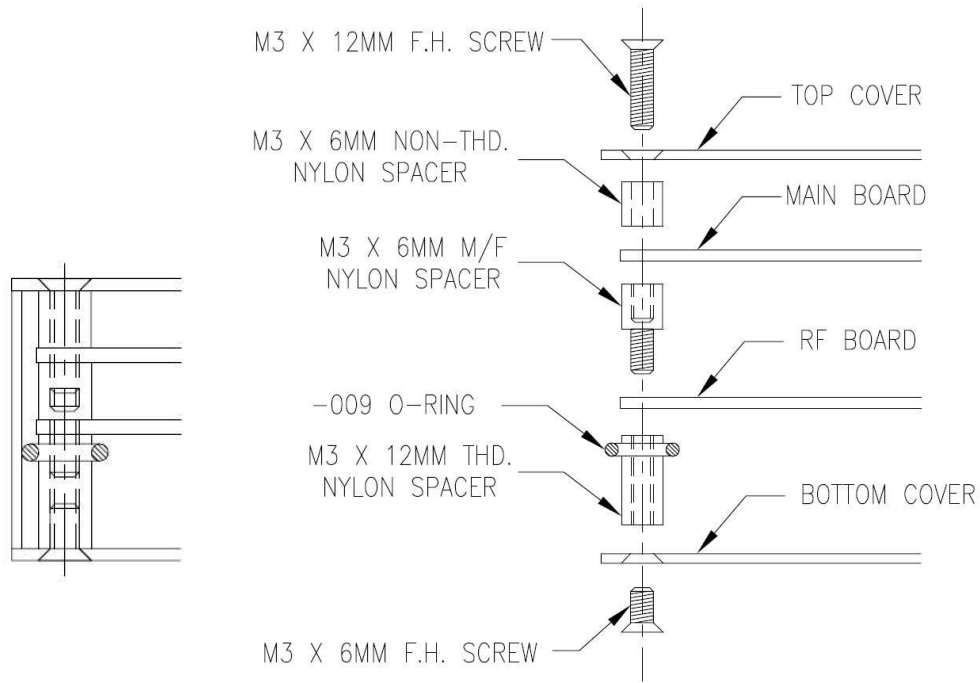

This is the corner hardware sequence

- [ ] Stretch the o-rings over the four M3 x 12mm nylon threaded spacers and attach them to the bottom cover with the M3 x 6mm flat head screws. Slide the o-rings near the top of the spacers. The four o-rings keep the side assembly centered with the top and bottom covers.

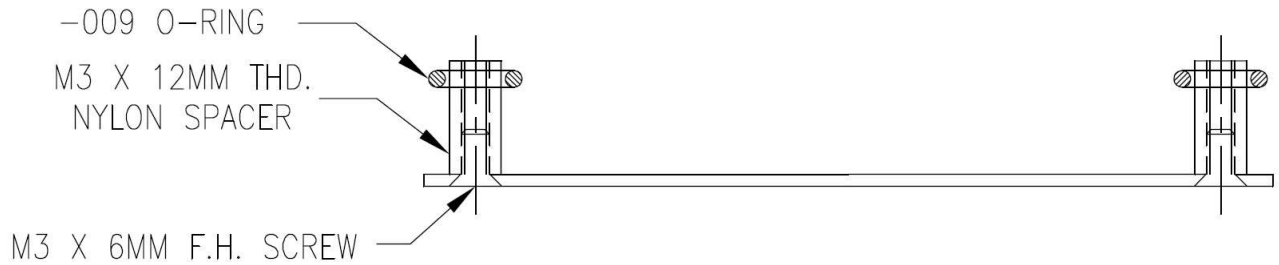

- [ ] Place the RF board on the four M3 x 12mm nylon spacers and secure with the M3 x 6mm M/F nylon spacers.

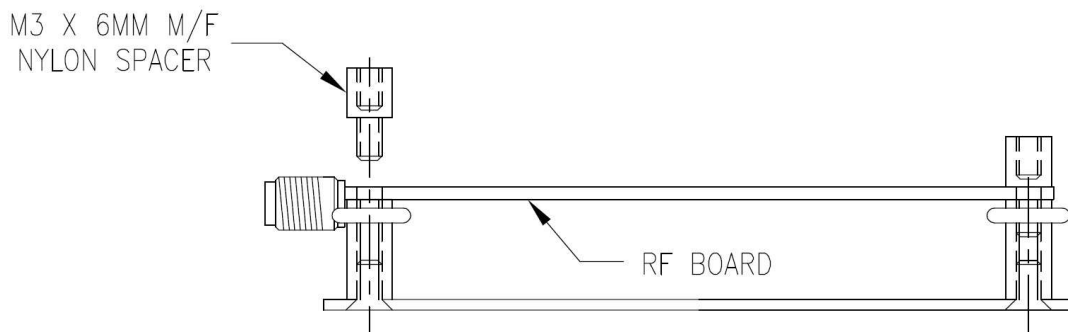

- [ ] Carefully spring open the side assembly enough to place around RF board allowing the SMA and other I/O connectors to protrude through the side assembly. Do not install the screws to the side assembly yet.

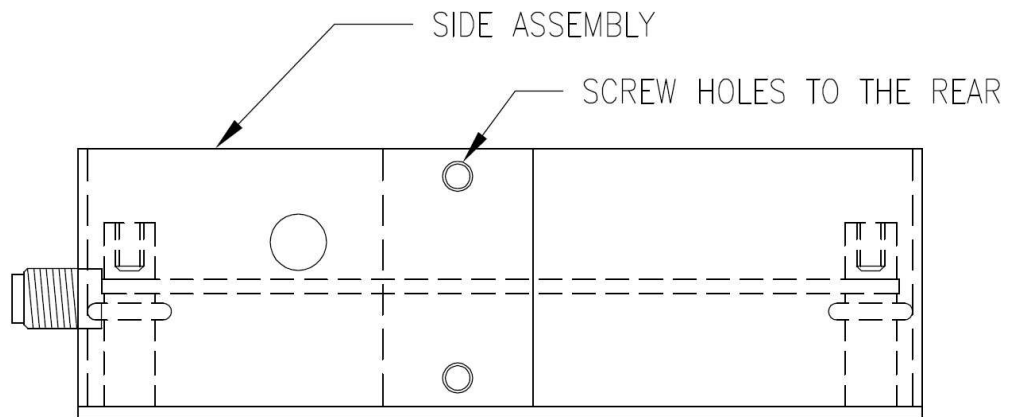

- [ ] Place the main board on the four M3 x 6mm M/F spacers while plugging in the SIP connector.

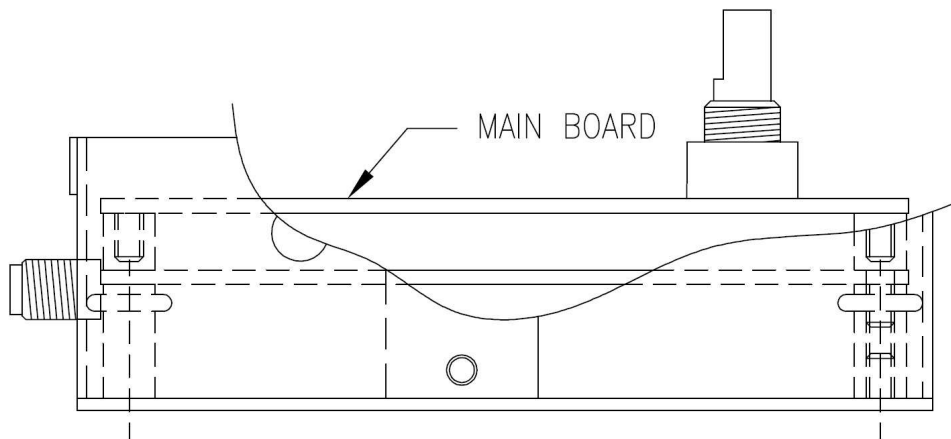

- [ ] Loosely install the two M3 x 5mm thin pan head screws into the side assembly. The o-rings will act as centering devices for the side assembly. Squeeze the side assembly against the o-rings and tighten the two pan head screws.

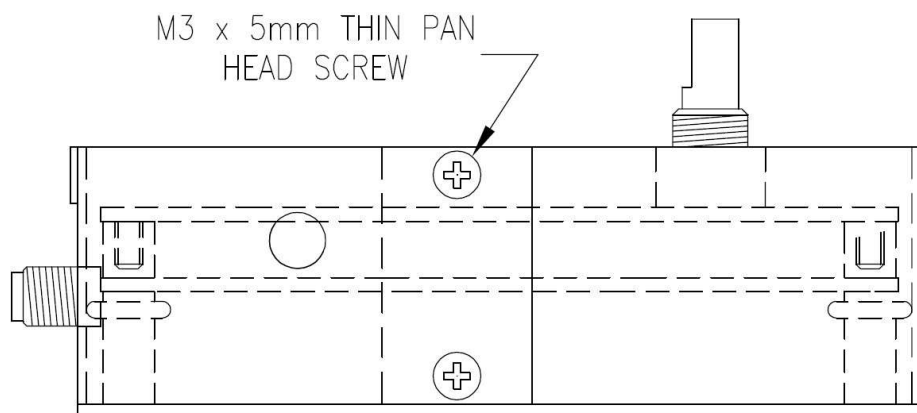

- [ ] Place the four M3 x 6mm non-threaded spacers at the four corners, align the speaker with the two small alignment holes in the cover, and secure the top cover with the four M3 x 12mm flat head screws. Reinstall the encoder washer, nut, and knob.

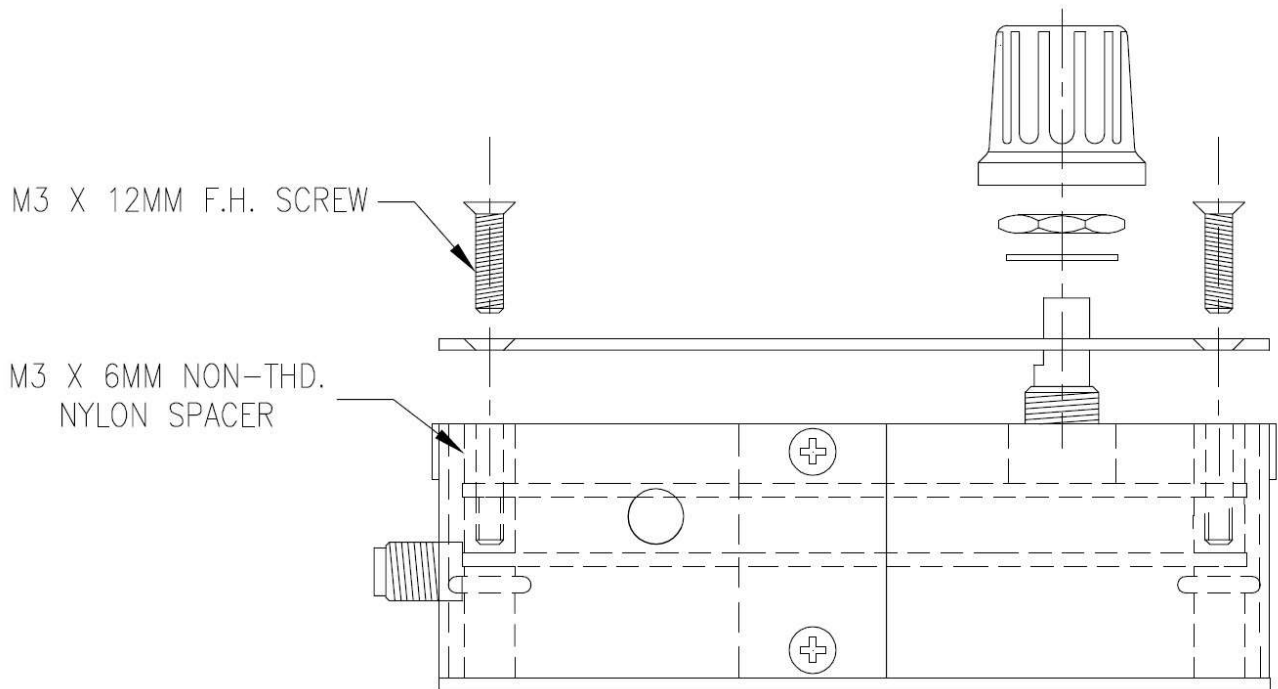

- [ ] Attach the four self-adhesive rubber feet on the bottom.

This completes the assembly. There is a space provided on the bottom cover for you to enter your individual serial #, the reference frequency from calibration, and check off the model you have.

Shielded case addendum:

Due to the design of the (tr)uSDX we have seen no change in the performance of the transceiver with a shielded vs. an unshielded case. Obviously the 3D printed plastic case is unshielded, and so is this anodized aluminum case, as the anodizing process is actually a form of an aluminum oxide coating. However, there still will be some that would like to have the case at ground potential. With the procedure below it can be accomplished with this addition.

The main board and rf board are grounded at many points through the SIP connector. So, all that remains is removing some of the anodizing around the screw hole under the top cover, bottom cover, and corner of the side assembly. Form a connection with a single thin strand of bare wire between the three points, and under one of the nylon spacers so it touches the ground annulus of RF board M3 corner pad. Use any one of the four corners.

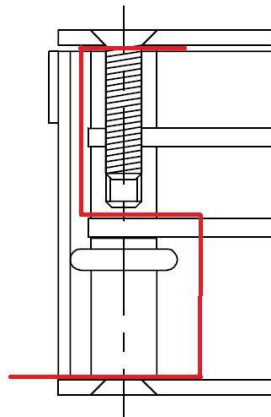
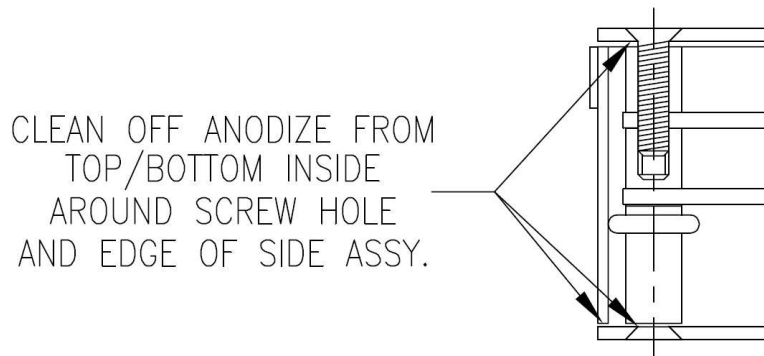

Route a single strand of bare wire (.005-.008") from a short piece of #24 or 26awg stranded wire as shown tying the three cleaned surfaces to the ground around the pcb hole. Clip the strand flush where it exits the case.