

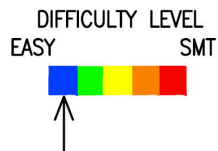

QRPGuys Digital Power Port



Shown with user supplied battery

First, familiarize yourself with the parts and check for all the components. If a part is missing, please contact us and we will send one. To request a part, please use qrpguys.parts@gmail.com.

Parts List

- 1 – QRPGuys Digital Power Port pcb
- 1 – S1, toggle switch – DPDT
- 1 – S2, pcb mount 6mm tactile switch
- 1 – FS1, 3.0A Polyfuse
- 1 – digital voltmeter module
- 1 – dc power connector, 2.1mm
- 2 – 2-56 x .375” long S.S. flathead screw
- 2 – 2-56 S.S. nut
- 2 – #2 x 3/16” O.D. x 1/8” long nylon spacer
- 1 – 6” long red/black 16awg zip cord
- 2 – .25” female spade crimp insulated terminal
- 2 – 8-32 x .75” long S.S. pan head screw
- 2 – 8-32 S.S. wing nut
- 2 - #8 S.S. internal tooth lock washer
- 4 – 8-32 S.S. nut
- 1 – piece of red film for digital display
- 1 – small nylon tie

Refer to the figures below for location of the individual components.

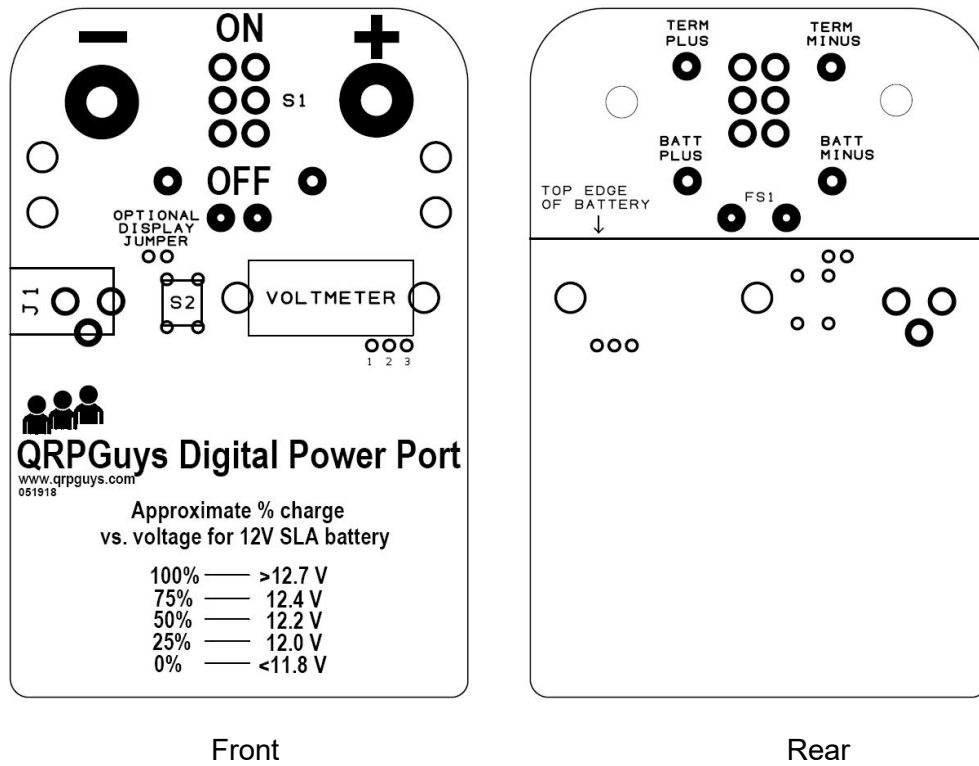

- [] Install S2, pcb mount 6mm tactile switch on the front of the pcb. Trim *flush* on the backside

Before mounting the digital voltmeter, it's a good idea to check the calibration of it with your DMM. There is a pcb mounted pot on the back of the digital voltmeter that you can adjust with a small screwdriver and match to your reading on a DVM. Twist the yellow and red wire together and attach to the "+" of a dc voltage source, and the black to the "-".

- [] Cut and strip the three wires of the digital voltmeter to 3/4" long. Feed the three wires through the holes marked 1,2,3, and fasten the digital voltmeter to the front of the pcb using the #2 hardware supplied as shown in the graphic below. Solder and trim the three leads *flush* on the backside. Trim the red film to the size of the digital readout and cement it to the surface of the display. *Some displays only have 2 leads. Simply add a third lead to the pad from one of the trimmed leads. If you have difficulty getting the nut to thread on the screw, slightly open the hole on the display to the outside with a small round file, or use the suggestion below.*

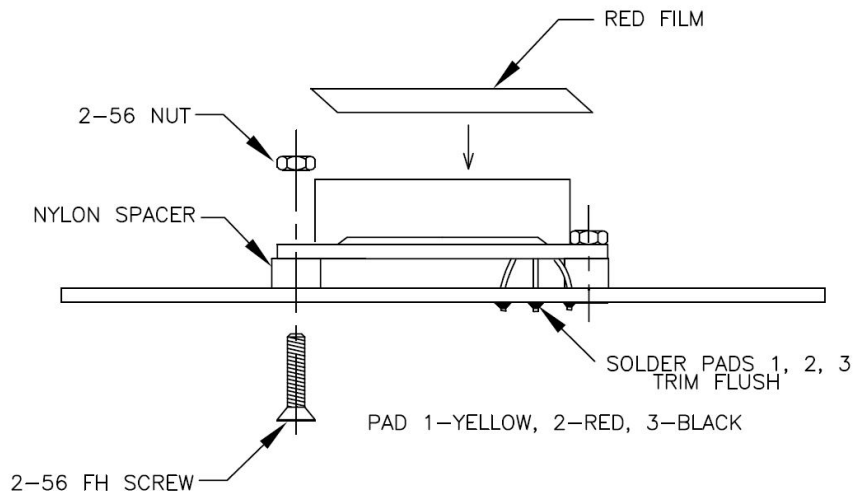

If your display has wires on the left side please refer to the addendum at the end to route the connections correctly.

It has been noted that there are some problems installing the small hardware associated with the digital voltmeter. In an ideal world, it is close and tedious. Variations in the placement of the digital readout on the small pcb can make it more difficult. If this is a problem in yours, we suggest filing a small flat on the 2-56 nut to give yourself a little more clearance. See the figure below.

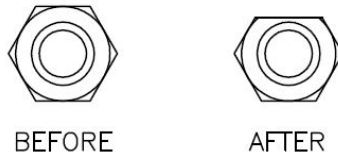

- [] Install S1, DPDT toggle switch on the front of the pcb, soldering all 6 terminals on the backside.
- [] Install J1, 2.1mm dc power connector on the front of the board, and trim *flush* on the backside.

Note: You may find the center pin on the connector does not fit the center hole on the pcb due to the different connector manufacturers used. The center pin is not used. If you encounter one of these, you can cut it off the center connector pin, squeeze it together and insert it in the hole, or slightly enlarge the hole.

- [] Install and firmly secure the terminal posts for the positive and negative connections on the front side of the board as shown in the figure below. The post screw should be flush with the securing nut on the back side.

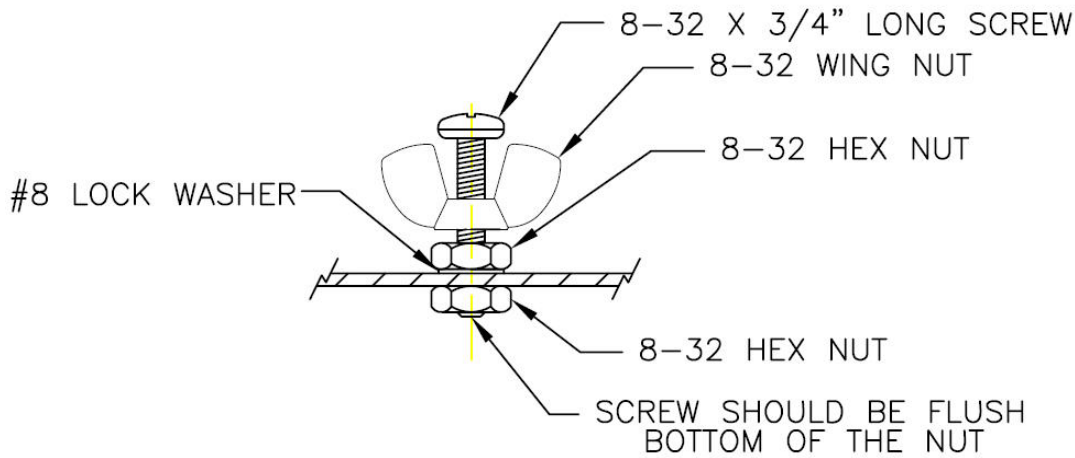

- [] Solder FS1, the Polyfuse to the backside of the pcb as shown below:

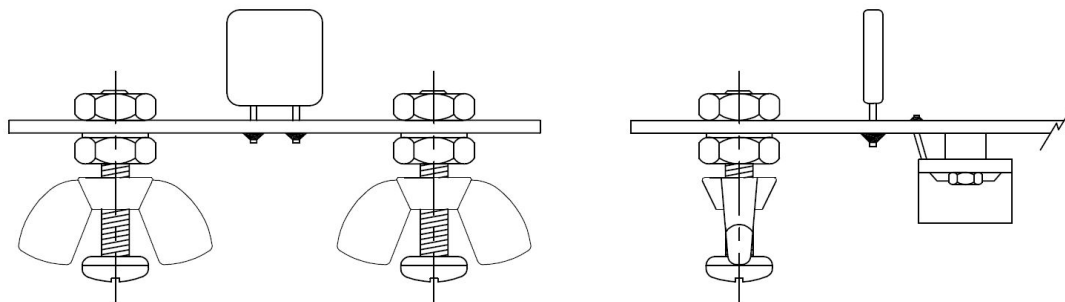

- [] Divide the red/black zip cord into two individual wires, and either securely crimp or solder one of the female spade connectors to each wire. Test fit where you want to attach your power port to the battery. Measure, route, and trim the wire length appropriately to each battery terminal. You might want to leave a little extra if you plan to move to different size batteries. Strip and solder the red wire to the "BATTERY PLUS" pad and the black wire to the "BATTERY MINUS" pad on the back of the pcb..
- [] The power port can attach to many size batteries. Shown below is the popular 12V, 7A/hr size. Fit the power port to your battery and secure it using two layers of 2" wide clear packaging tape. You can secure it to either end of the battery, or even in the center of one side.

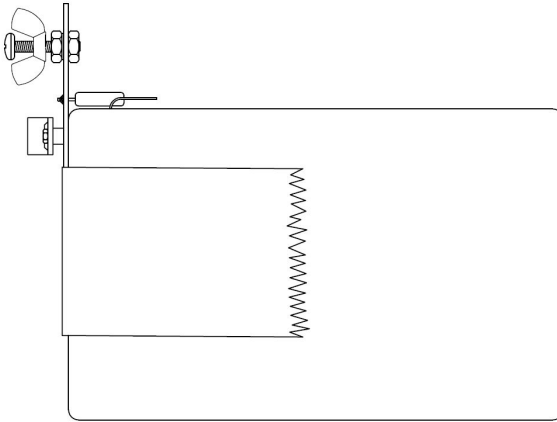

- [] Connect your spade terminals to the correct battery terminals.

This completes the assembly

Usage:

Remember to turn off the toggle switch when transporting the battery. The voltmeter will indicate the present voltage of the battery with the toggle switch in the **on** or **off** position when the pushbutton is pushed and held for 1 sec. The Polyfuse is rated at a *hold* current of 3.0A and a *trip* current of 5.1A. There are many Polyfuse current selections available from suppliers if you would like a different value. The board is conservatively rated and manufactured with the equivalent of 2oz. copper, but we do not recommend any higher currents without modification.

There are two holes either side of the wingnuts to secure a power cord with a small nylon tie for strain relief.

When attached to a battery, J1 is provided for charging the battery. **A tip from Doug, use the device without attaching it to an SLA battery as a simple volt meter to check your batteries by plugging into J1 before venturing out into the field.**



Optional display jumper

When the optional display pads are jumpered, the display will show the battery voltage continuously while the main power switch (S1) is in the **on** position. The voltmeter draws 16mA of current. So only install this jumper if that is acceptable. If the jumper is installed, the push button switch (S2) will still activate the voltmeter if the main power switch (S1) is in the **off** position.

Reference:

The site below is an excellent source of information for the care and feeding of SLA batteries.

http://www.power-sonic.com/images/powersonic/technical/1277751263_20100627-TechManual-Lo.pdf

I have used a Deltran Battery Tender Junior charging 12V SLA's for years with no problems.

<http://products.batterytender.com/Chargers/Battery-Tender-Junior-12V-0-75A.html>

Deltran also has a switchable model that will charge SLA and the new 12V Lithium (LiFePO4) batteries we are starting to see, for a little more money.

<http://products.batterytender.com/Chargers/PN-021-0199-DL-WH.html>

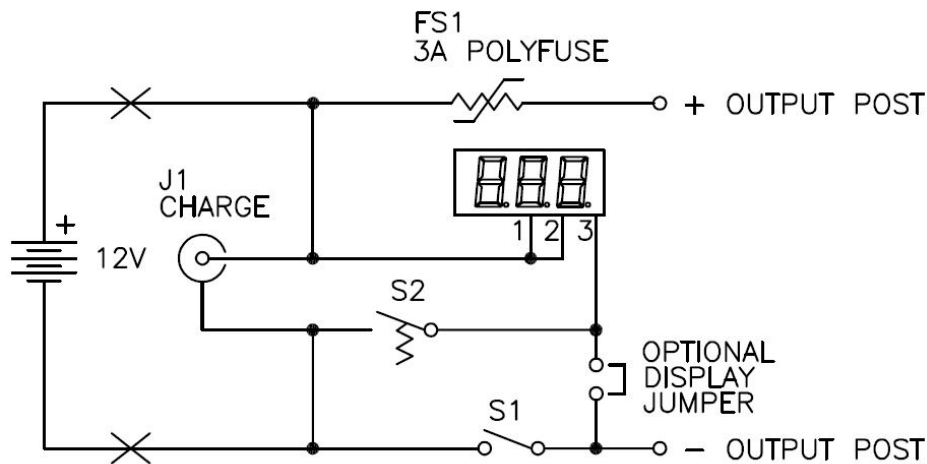

Notes:

Addendum:

Some of the digital displays have connecting wires on the left side as shown below. Connect the black wire to hole #3, connect the red wire to hole #2, yellow wire to hole#1.

